

IT9312

SHOULDER PRESS

OWNER'S MANUAL



! CAUTION

Read all precautions
and instructions in this manual
before using this equipment

14Z Rev G

! CAUTION

Read all precautions and instructions in this manual before using this equipment.

Table Of Contents

Important Safety Instructions-----	3
Instructions-----	5
Parts List-----	6
Exploded View-----	8
Measurement Guide-----	10
Assembly Instructions-----	11
Assembly-----	12
Adjust Instructions-----	24
Exercise Instructions-----	25
Maintenance Schedule-----	26
General Maintenance Information-----	27
Weight Training Tips-----	28

Please assemble according to the actual **Weights and Shroud** you buy !

Important Safety Instructions

Before beginning any fitness program, you should obtain a complete physical examination from your physician. When using exercise equipment, basic precautions should always be taken, including the following:

1. Read all instructions before using the equipment.
These instructions are written to ensure your safety and to protect the unit.
2. Use the equipment only for its intended purpose as described in this guide.
Do not use accessory attachments that are not recommended by the manufacturer: such attachments might cause injuries.
3. The product should only be used on a level surface and is with 0.5 meters space around the product.
Do not use the equipment outdoors.
4. Do not allow children on or near the equipment. And children are not allowed to use this equipment.
Teenagers should use this equipment with adult supervision.
5. Do not overexert yourself or work to exhaustion.
Do not attempt to lift more weight than you can control safely.
If you feel any pain or abnormal symptoms, stop your workout immediately and consult your physician.
6. This equipment is not used as medical apparatus and instruments.
7. Never operate the unit when it has been dropped or damaged.
Never drop or insert anything into any opening in the equipment.
Always check the unit and its cables before each use. Make sure that all fasteners and cables are secure and in good working condition.
Frayed or worn cables can be dangerous and may cause injury. Periodically check these cables for any indication of wear.
Keep hands, limbs, loose clothing and long hair well out of the way of moving parts.
8. Be careful when getting on or off the equipment.
9. Wear proper exercise clothing and shoes for your workout, no loose clothing.

Important Safety Instructions

Personal Safety During Assembly

Read each step in the assembly instructions and follow the steps in sequence. Do not skip ahead. If you skip ahead, you may learn later that you have to disassemble components and that you may have damaged the equipment.

Assemble and operate the equipment on a solid, level surface. Locate the unit a few feet from walls or furniture to provide easy access. The equipment is designed for your enjoyment. By following these precautions and using common sense, you will have many safe and pleasurable hours of healthful exercise with the equipment.

Training Area and Free Area

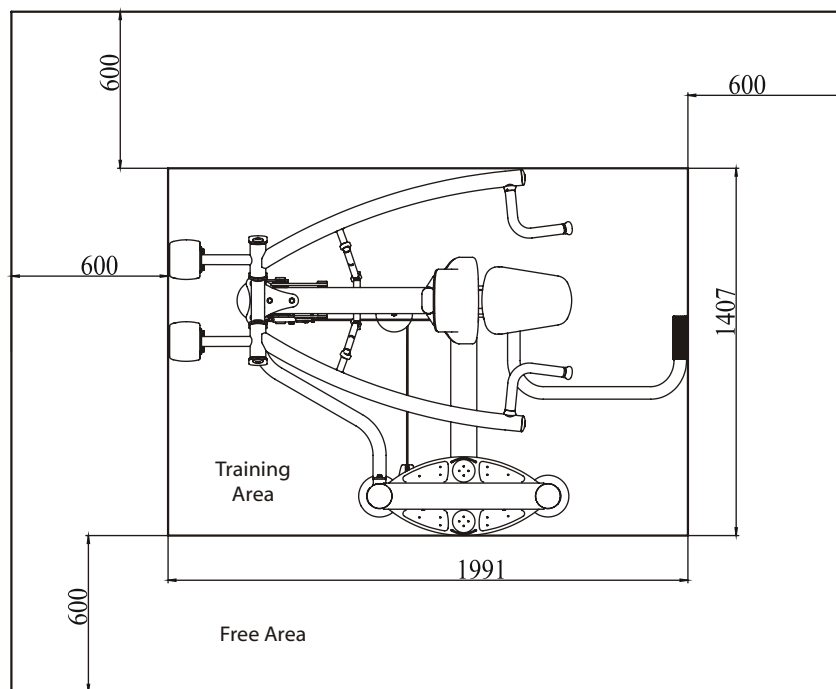

Specifications

Class: S

Maximum Wt. Capacity: 125kg/ 275lbs

Maximum User Weight: 150kg/ 330lbs

Product Total Surface: 1991*1407mm

Product Total Mass (Short Shroud): 150.5kg/ 332lbs

Instructions

Before beginning assembly please take the time to read instructions thoroughly. Please use the various lists in this manual to make sure that all parts have been included in your shipment. When ordering, use part number and description from the lists. Use only our replacement part when servicing. Failure to do so will void your warranty and could result in personal injury.

The equipment is designed to provide the smoothest, most effective exercise motion possible. After assembly, you should check all functions to ensure correct operation. If you experience problems, first recheck the assembly instructions to locate any possible errors made during assembly. If you are unable to correct the problem, call your authorized dealer. Be sure to have your serial number and this manual when calling. When all parts have been accounted for, continue on.

Tools Required



Ratchet Wrench and Socket



Adjustable Wrench



Rubber Mallet

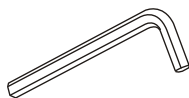

Hex Key Wrench Set



Phillips Screwdriver

Parts List

NOTE: SOME OF THESE PARTS MAY COME PRE-INSTALLED.

Item No.	Description	Qty	Item No.	Description	Qty
1	Weight Stack Frame	1	32	4.5" Pulley	7
2	Main Frame	1	33	Back Pad	1
3	Top Cross Brace	1	34	Seat Pad	1
4	Sway Pulley Bracket	1	35	Guide Rod $\Phi 19 \times 1177$	2
5	Big Rolling Frame	1	36	Plug $\Phi 95.4 \times 61$	2
6	Small Rolling Frame	1	37	Shroud	1
7	Left Press Arm	1	38	Top Rear Shroud	1
8	Right Press Arm	1	39	Top Front Shroud	1
10	Sway Bracket	1	40	Front Support	1
11	Bottom Cross Brace	1	41	Arc Bracket	1
12	Seat Pad Support	1	42	Side Cover	2
13	Rod $\Phi 25 \times 480$	2	43	Plastic Block	12
14	Pivot Axle $\Phi 25.4 \times 144$	2	44	L Bracket	2
15	Pivot Axle $\Phi 25.4 \times 158$	1	45	Gas Spring	1
16	Pivot Axle $\Phi 34 \times \Phi 25.8 \times 6$	2	46	Aluminium Cap $\Phi 60 \times \Phi 10.5 \times 10$	1
17	Rubber Counterweight	2	47	Aluminium Cap $\Phi 60 \times \Phi 10.5 \times 10.9$	2
18	Support Axle $\Phi 25.4 \times M10 \times 130$	1	48	Aluminium Cap $\Phi 50 \times \Phi 10.5 \times 8$	6
19	Plastic Spacer $\Phi 35 \times \Phi 25.3 \times 114.5$	1	49	Bearing $\Phi 50.8 \times \Phi 25.4 \times 15.9$	10
20	Top Frame	1	50	Tie Rod End 1/2"-13	2
21	Aluminium Grip Ring	2	51	Tie Rod End M16 \times $\Phi 16$	2
22	Grip	2	52	Rubber Sleeve $\Phi 32 \times \Phi 25.3 \times 35$	1
23	Shoulder Press Cable	1	53	Foot Sleeve $\Phi 48 \times \Phi 56 \times 164$	1
24	Spare Cable	1	54	Weight Rubber Bumper	2
25	Adjustable Foot Plate	4	55	Adjustable Support Sleeve	1
26	Adjustable Support	1	56	Spring	1
27	Top Plate	1	57	Plastic Tube Guide	2
28	Plug Rt50 \times 100	1	58	Pulley Cover	9
29	Front Shroud	1	59	Button $\Phi 8 \times \Phi 20 \times 23$	19
30	Rear Shroud	1	60	Connect Button $\Phi 18 \times 12$	4
31	Selector Pin W/Coil	1	61	Short Shroud Retainer Plate	2

Parts List

NOTE: SOME OF THESE PARTS MAY COME PRE-INSTALLED.

Item No.	Description	Qty	Item No.	Description	Qty
62	Hex Head Bolt M10*135	4	92	Hex Key S=8	1
63	Hex Head Bolt M8*30	2	93	Hex Key S=12	1
64	Hex Head Bolt M10*100	2	94	Hex Key S=3/32"	1
65	Hex Head Bolt M10*50	2	95	Wrench	1
66	Hex Head Bolt M10*30	8	96	Lube	1
67	Hex Head Bolt M10*25	4	98	Tie Rod End M16*Φ16 (Left)	2
68	Button Head Cap Screw M8*55	1	99	Hex Nut M16 (Left)	2
69	Hex Head Bolt M10*45	1	101	Hex Key S=4	1
70	Hex Head Bolt M12*40	2	102	Hex Head Bolt M10*80	2
71	Socket Head Cap Screw M10*50	5	103	Aluminium Cap Φ38*Φ10.5*8	2
72	Socket Head Cap Screw M8*30	1	104	Flat Head Cap Screw M10*25	9
73	Socket Head Cap Screw M16*40	4	105	Aluminium Grip Cap	2
74	Button Head Cap Screw M6*12	2	106	Cable End	1
75	Hex Head Bolt M10*20	2	107	Spacer Φ10*Φ14*20	1
76	Flat Head Cap Screw M10*30	4	108	Shroud Retainer Plate	3
77	Flat Philips Screw M5*16	17	109	Nut	2
78	Self-Tapping Screw St4.2*10	4	110	Cushion	1
79	Flat Washer Φ13*Φ24*1.5	2	111	Top Rear Shroud-A	1
80	Flat Washer Φ11*Φ20*2	39	112	Rear Support	1
81	Flat Washer Φ9*Φ16*1.6	2	113	Flat Philips Screw M5*25	2
82	Hex Nut M6	2	114	Tapped Hole Nut M8	2
83	Hex Nut M16	2	115	Rubber Plug Φ29*Φ19*10	2
84	Nylon Lock Nut M8	2	116	Spring Washer Φ8	2
85	Nylon Lock Nut M10	18	117	Plug 48*22.7*R48	2
86	Nylon Lock Nut M12	2	118	Button Φ8.1*7	10
87	Socket Set Screw 10-32*3.2	4	119	Flat Washer Φ9*Φ22*1.6	2
88	Plastic Cover Φ21*5.7	4	120	Right Short Shroud Retainer Plate	1
89	Plastic Washer Φ13*3	4	125	Socket Set Screw M6*15	2
90	Hex Key S=5	1	126	Hex Key S=3	1
91	Hex Key S=6	1			

Exploded View

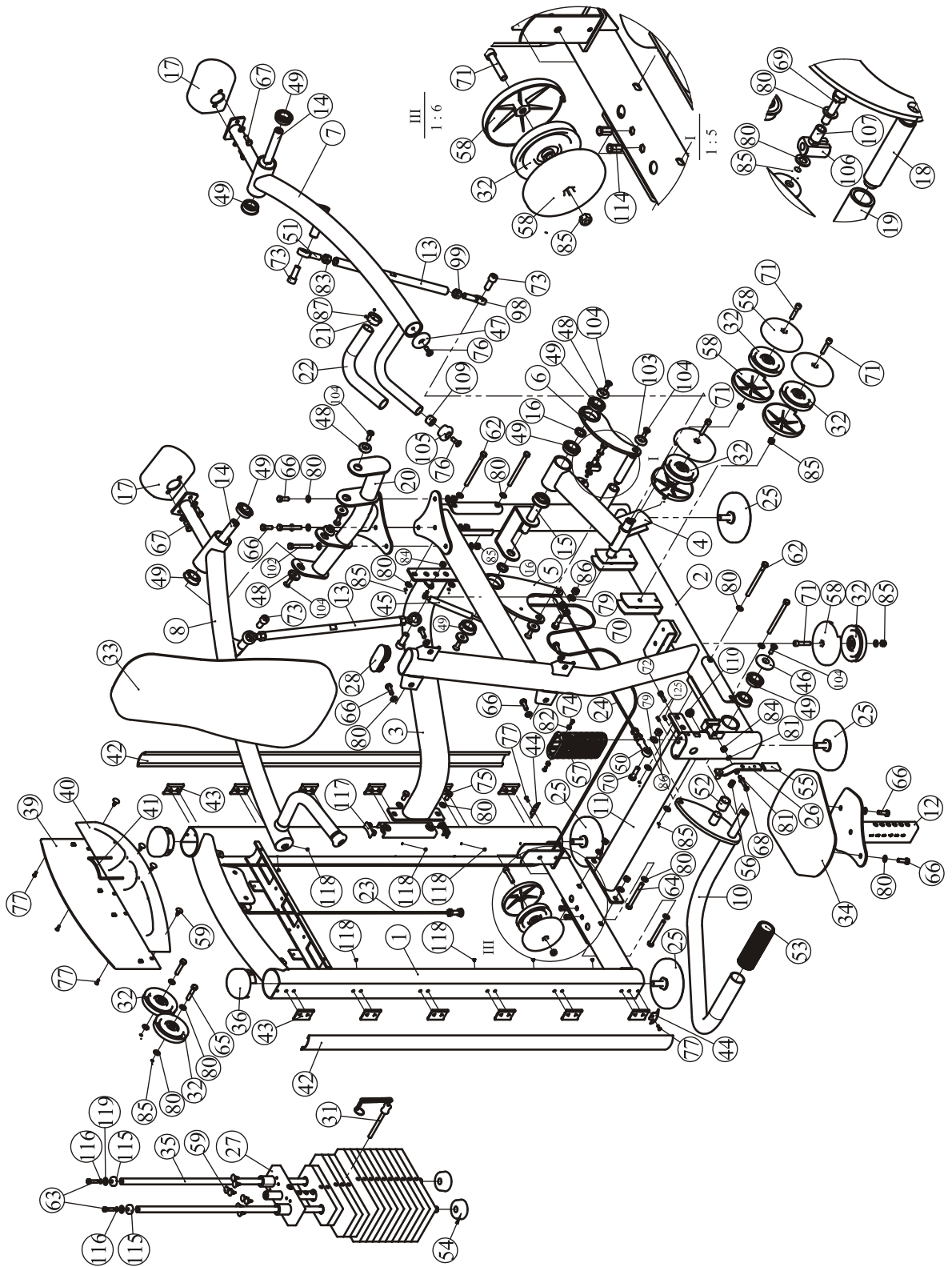

Exploded View

Flat Shroud

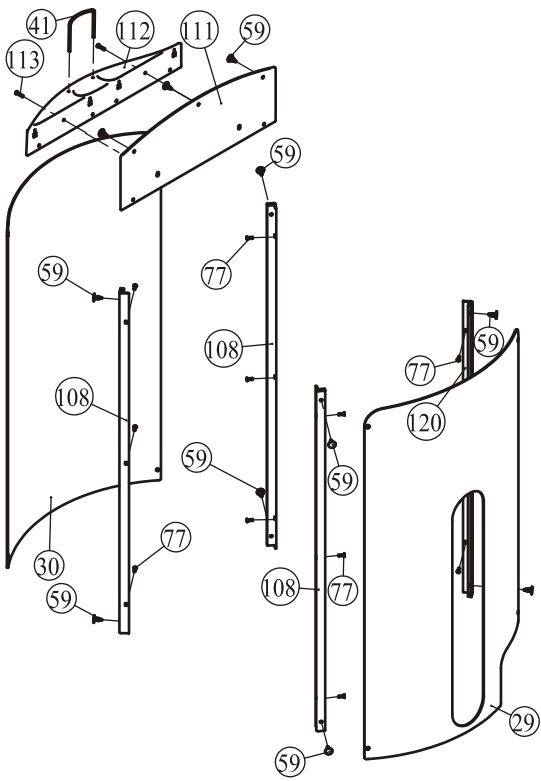

Molding Shroud

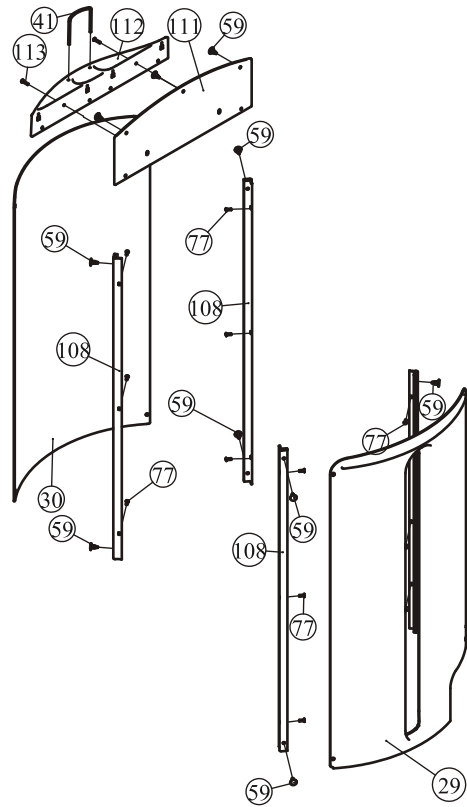

Short Shroud

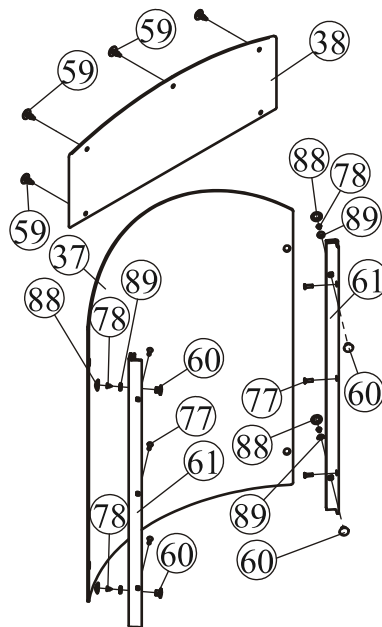

Measurement Guide

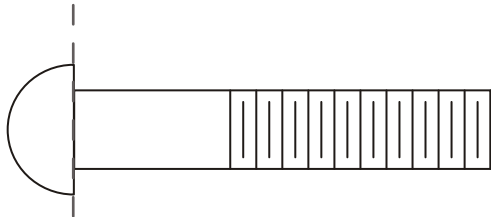

BHCS = Button Head Cap Screw

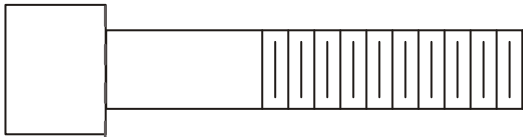

SHCS = Socket Head Cap Screw

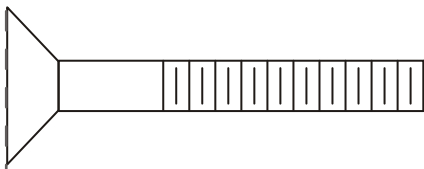

FHCS = Flat Head Cap Screw

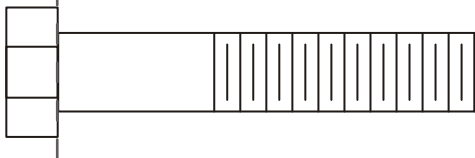

HHB = Hex Head Bolt

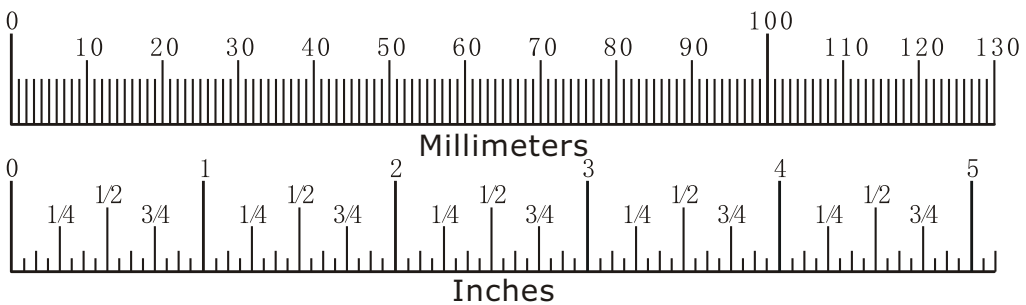

Diameter of bolt (mm/inch)	M6(1/4")	M8(5/16")	M10(3/8")	M12(1/2")	M16(5/8")
Tightening torque (N.m)	9~12	22~30	45~59	78~104	193~257
Operational methods for adult men	The strength of the wrist	The strength of the wrist and forearm	The strength of the entire arm	The strength of the arm and upper body	with all strength

Assembly Instructions

Assembly of the equipment takes professional installers about 2 hours. If this is the first time you have assembled this type of equipment, plan to spend more time. It is strongly recommended to assemble the equipment by professional installers. You may find it quicker, safer, easier to assemble this equipment with the help of a friend, as some of components may be large, heavy or awkward to handle alone. It is important that you assemble your product in a clean, clear, uncluttered area. This will enable you to move around the product while you are fitting components and reduce the possibility of injury during assembly.

NOTE

As with any assembled part, proper alignment and adjustment is critical. While tightening the fasteners, be sure to leave room for adjustments. Do not fully tighten the fasteners until instructed to do so. Be careful to assemble the components in the sequence presented in this guide.

Assembly

STEP 1

1. Attach two Adjustable Foot plate (#25) to the Weight Stack Frame (#1).
2. Attach three Shroud Retainer Plate (#108) and one Right Short Shroud Retainer Plate (#120) to the Weight Stack Frame (#1), using:
twelve M5*16 Flat Philips Screws (#77)

Note: Wrench Tighten Screws.

Here is the assembly instruction for **Flat Shroud and Molding Shroud !**

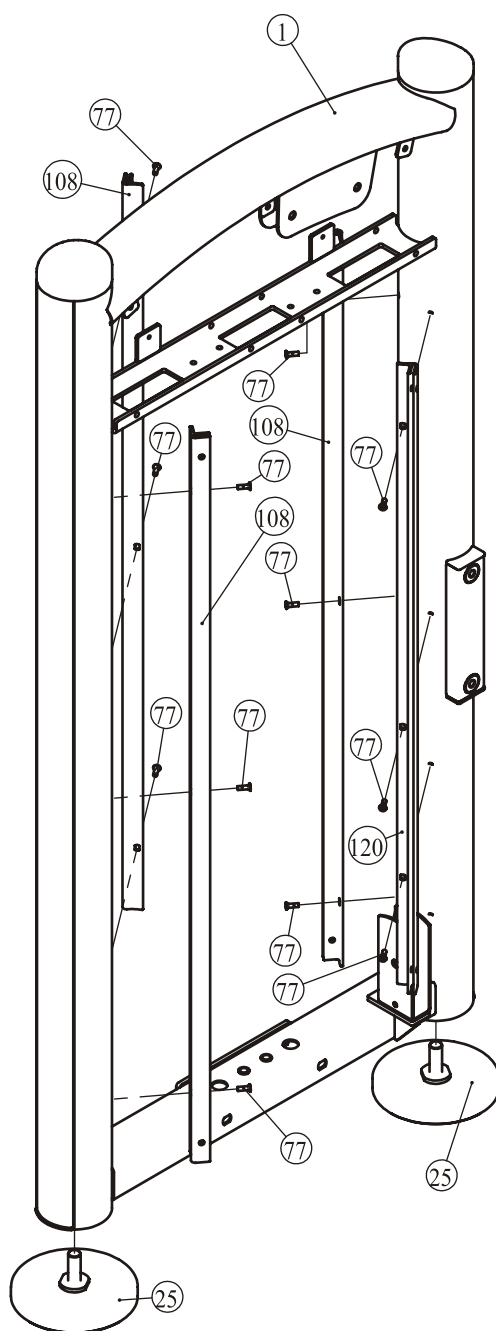

Assembly

STEP 1

1. Attach two Adjustable Foot plate (#25) to the Weight Stack Frame (#1).
2. Attach two Short Shroud Retainer Plate (#61) to the Weight Stack Frame (#1) using:
six M5*16 Flat Philips Screws (#77)
3. Attach nine $\Phi 8.1 \times 7$ Buttons (#118) to the Weight Stack Frame (#1).

Note: Wrench Tighten Screws.

Here is the assembly instruction for **Short Shroud !**

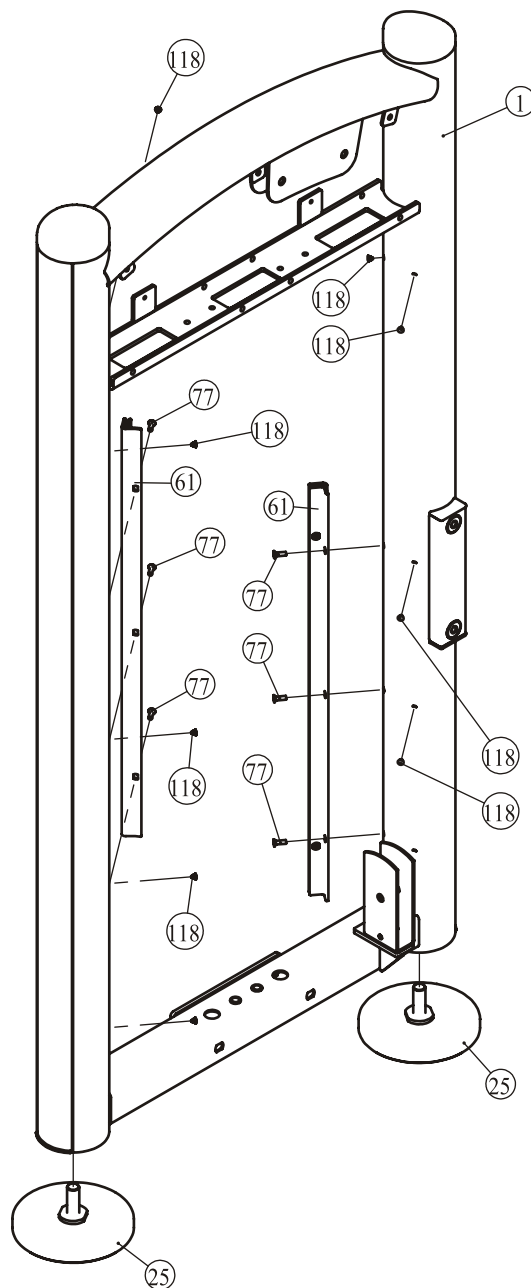

Assembly

STEP 2

1. Attach two Adjustable Foot plate (#25) to the Main Frame (#2).
2. Attach the Bottom Cross Brace (#11) to the Weight Stack Frame (#1) using:
two M10*100 HHB (#64) four $\Phi 11*\Phi 20*2$ Flat Washers (#80)
two M10 Nylon lock Nuts (#85)
3. Attach the Bottom Cross Brace (#11) to the Main Frame (#2) using:
two M10*135 HHB (#62) four $\Phi 11*\Phi 20*2$ Flat Washers (#80)
two M10 Nylon lock Nuts (#85)
4. Attach the Top Cross Brace (#3) to the Weight Stack Frame (#1) using:
two M10*20 HHB (#75) two $\Phi 11*\Phi 20*2$ Flat Washers (#80)
5. Attach the Top Cross Brace (#3) to the Main Frame (#2) using:
two M10*135 HHB (#62) four $\Phi 11*\Phi 20*2$ Flat Washers (#80)
two M10 Nylon lock Nuts (#85)
6. Attach the Top Frame (#20) to the Main Frame (#2) using:
two M10*80 HHB (#102) two M10*30 HHB (#66)
eight $\Phi 11*\Phi 20*2$ Flat Washers (#80) four M10 Nylon lock Nuts (#85)
7. Attach the Gas Spring (#45) to the Big Rolling Frame (#5) and Top Cross Brace (#3) using:
one M8 Nylon lock Nut (#84)

Note: Hand tighten Bolts and Nylon Lock nuts.

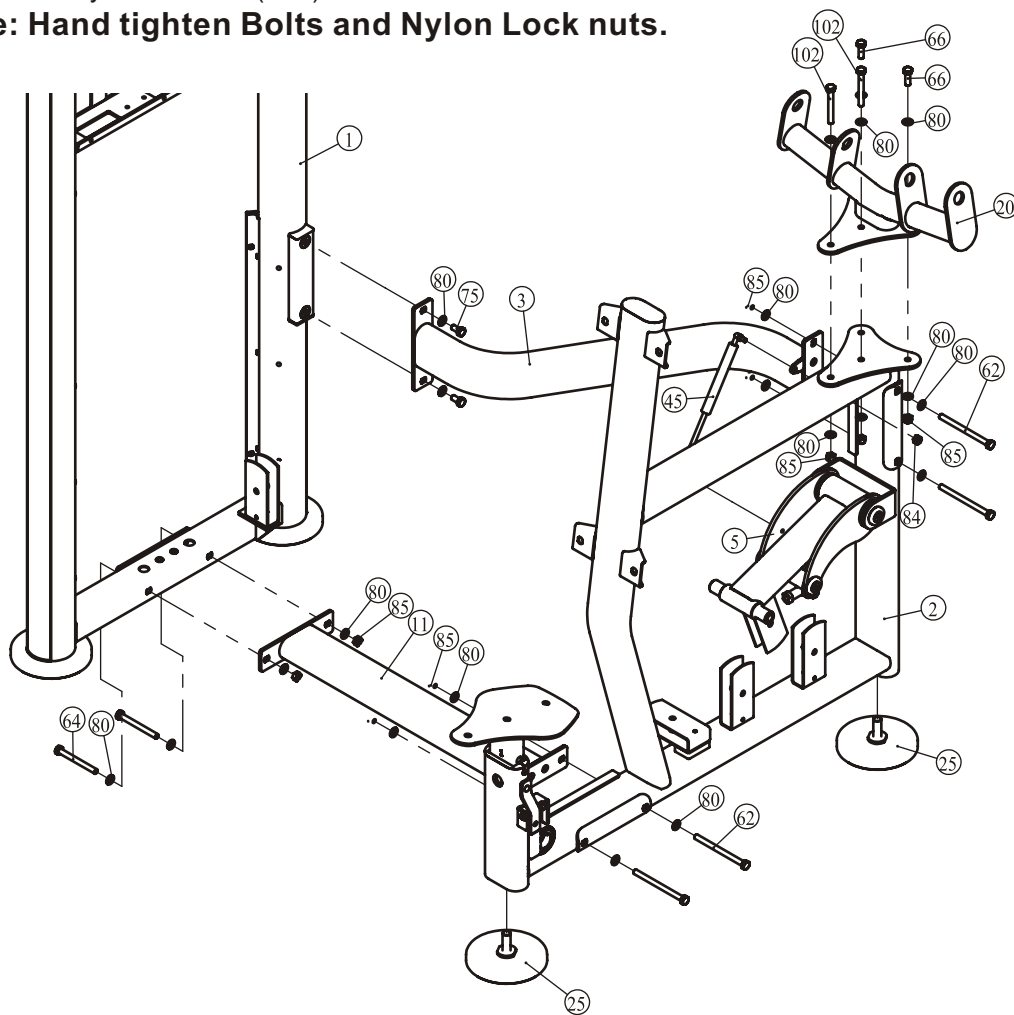

Assembly

STEP 3

1. Attach the Left Press Arm (#7) to the Top Frame (#20) using:
two M10*25 FHCS (#104) two $\Phi 50*\Phi 10.5*8$ Aluminium Cap (#48)
one $\Phi 25.4*144$ Pivot Axle (#14)
2. Attach the Right Press Arm (#8) to the Top Frame (#20) using:
two M10*25 FHCS (#104) two $\Phi 50*\Phi 10.5*8$ Aluminium Cap (#48)
one $\Phi 25.4*144$ Pivot Axle (#14)
3. Attach one Rod (#13) to the Left Press Arm (#7) and the Sway Pulley Bracket (#4) using:
two M16*40 SHCS (#73)
4. Attach another Rod (#13) to the Right Press Arm (#8) and the Sway Pulley Bracket (#4) using:
two M16*40 SHCS (#73)
5. Attach the Sway Bracket (#10) to the Main Frame (#2) using:
one M10*25 FHCS (#104) one $\Phi 60*\Phi 10.5*10$ Aluminium Cap (#46)

Note: Wrench Tighten Bolts and Nylon Lock nuts.

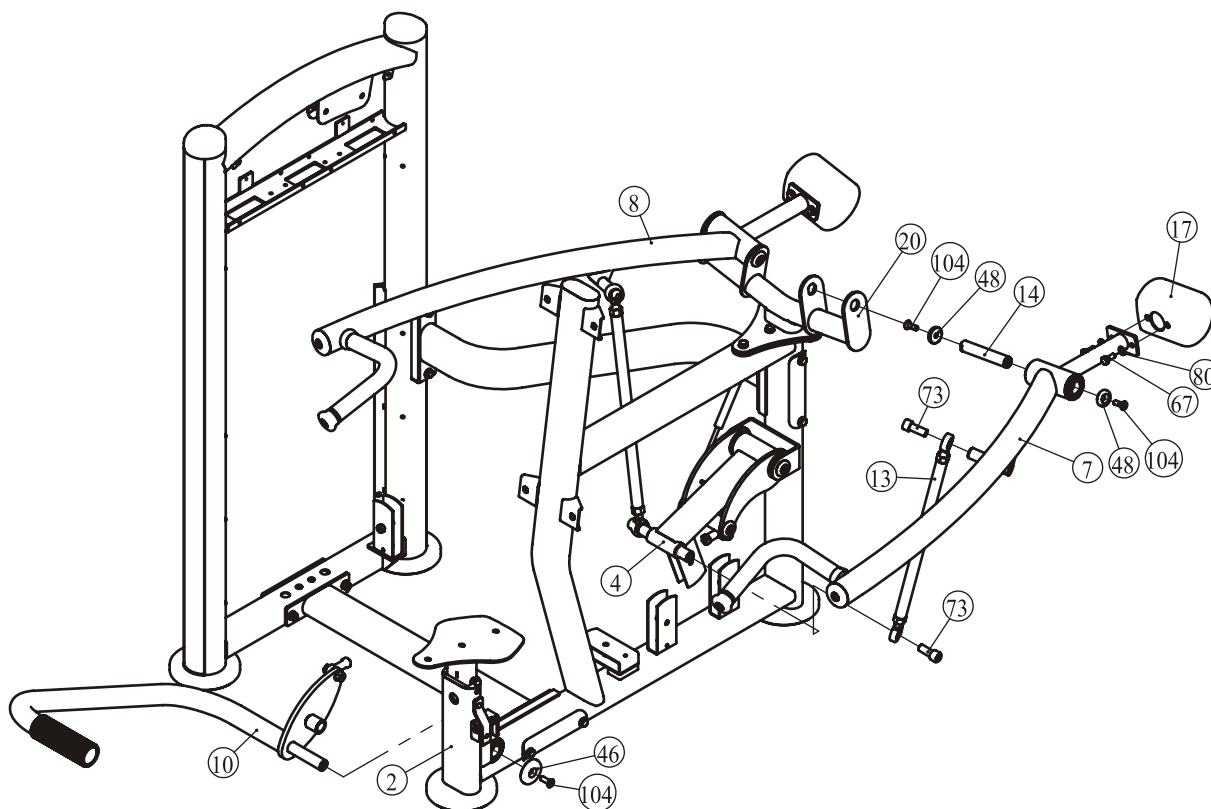

Assembly

STEP 4

1. Attach:

two $\Phi 19 \times 1177$ Guide Rods (#35)
 ten Weight Plate 15LBS (#124)
 two Weight Plate 5LBS (#122)

two $\Phi 63.5 \times \Phi 19 \times 25.4$ Weight Rubber Bumper (#54)
 three Weight Plate 10LBS (#123)
 one Top Plate (#27)

to the Weight Stack Frame (#1) using:

two M8*30 HHB (#63)

two $\Phi 8$ Spring Washers (#116)

two $\Phi 9 \times \Phi 22 \times 1.6$ Flat Washers (#119)

two $\Phi 29 \times \Phi 19 \times 10$ Rubber Plugs (#115)

2. Attach the Selector Pin W/Coil (#31) to the Top Plate (#27).

3. Attach eight $\Phi 8 \times \Phi 20 \times 23$ Buttons (#59) to the Top Plate (#27).

Note: Wrench Tighten Bolts and Nylon Lock nuts.

Here is the assembly instruction for **200LBS Weights** !

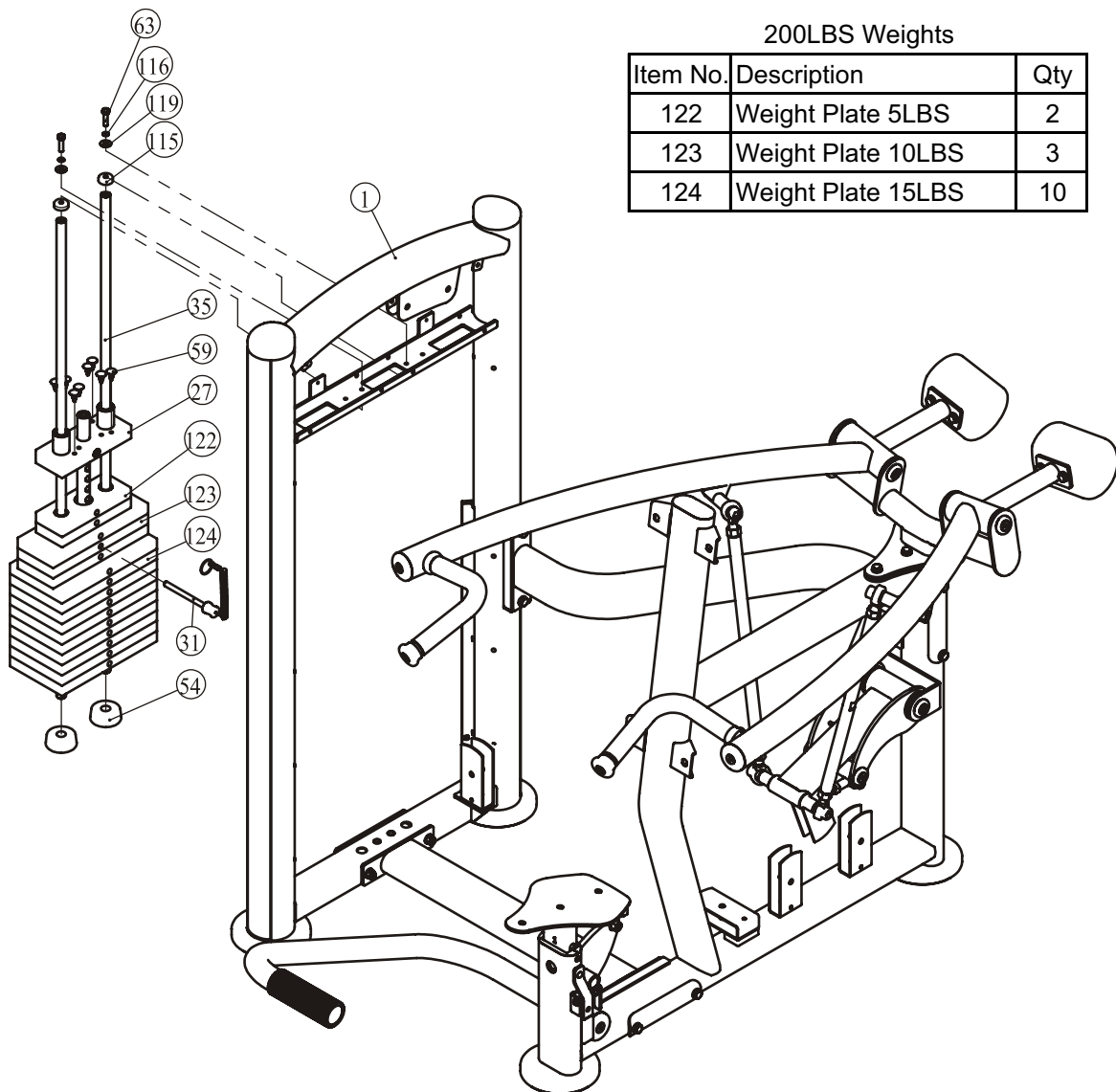

Assembly

STEP 4

1. Attach:

two $\Phi 19 \times 1177$ Guide Rods (#35)
 ten Weight Plate 20LBS (#124)
 two Weight Plate 10LBS (#122)

two $\Phi 63.5 \times \Phi 19 \times 25.4$ Weight Rubber Bumper (#54)
 three Weight Plate 15LBS (#123)
 one Top Plate (#27)

to the Weight Stack Frame (#1) using:

two M8*30 HHB (#63)

two $\Phi 8$ Spring Washers (#116)

two $\Phi 9 \times \Phi 22 \times 1.6$ Flat Washers (#119)

two $\Phi 29 \times \Phi 19 \times 10$ Rubber Plugs (#115)

2. Attach the Selector Pin W/Coil (#31) to the Top Plate (#27).

3. Attach eight $\Phi 8 \times \Phi 20 \times 23$ Buttons (#59) to the Top Plate (#27).

Note: Wrench Tighten Bolts and Nylon Lock nuts.

Here is the assembly instruction for **275LBS Weights !**

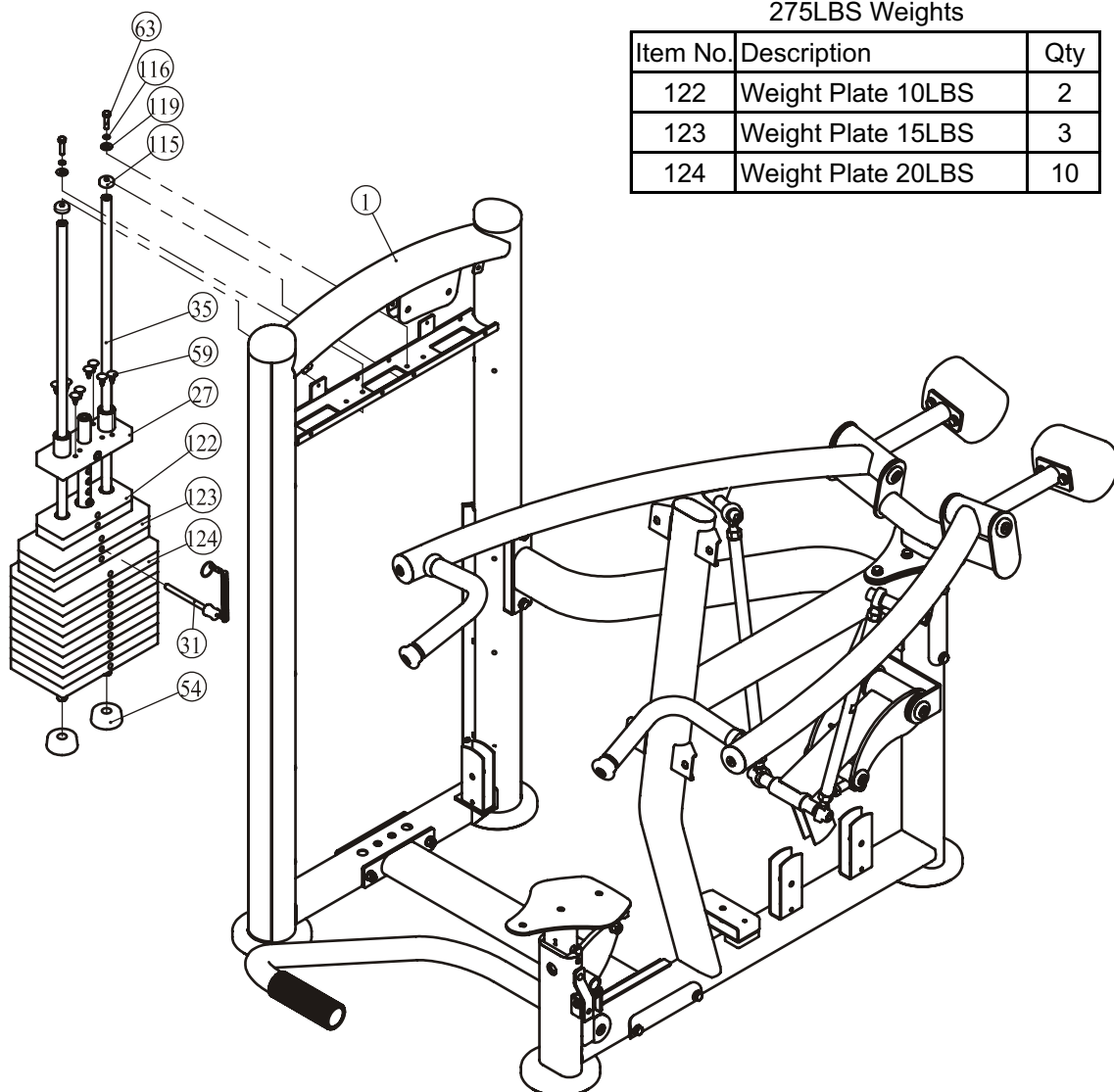

Assembly

STEP 5

1. Attach the Shoulder Press Cable (#23) to the Top Plate (#27).
2. Attach two 4.5" Pulley (#32) to the Weight Stack Frame (#1) using:
 - two M10*50 HHB (#65)
 - four $\Phi 11*\Phi 20*2$ Flat Washer (#80)
 - two M10 Nylon lock Nut (#85)
3. Attach one 4.5" Pulley (#32) to the Weight Stack Frame (#1) using:
 - two Pulley Cover (#58)
 - one M10*50 SHCS (#71)
 - one M10 Nylon lock Nut (#85)
4. Attach three 4.5" Pulley (#32) to the Main Frame (#2) using:
 - five Pulley Cover (#58)
 - three M10*50 SHCS (#71)
 - one $\Phi 11*\Phi 20*2$ Flat Washer (#80)
 - three M10 Nylon lock Nut (#85)
5. Attach one 4.5" Pulley (#32) to the Sway Pulley Bracket (#4) using:
 - one M10*50 SHCS (#71)
 - two Pulley Cover (#58)
 - one M10 Nylon lock Nut (#85)
6. Attach the Shoulder Press Cable (#23) to the Sway Pulley Bracket (#4) using:
 - one M10*45 HHB (#69)
 - two $\Phi 11*\Phi 20*2$ Flat Washer (#80)
 - one M10 Nylon lock Nut (#85)
 - one Cable End (#106)
 - one $\Phi 10*\Phi 14*20$ Spacer (#107)
7. Attach the Spare Cable (#24) to two Tie Rod End 1/2"-13 (#50).

Note: Wrench Tighten Bolts and Nylon Lock nuts.

Assembly

STEP 5

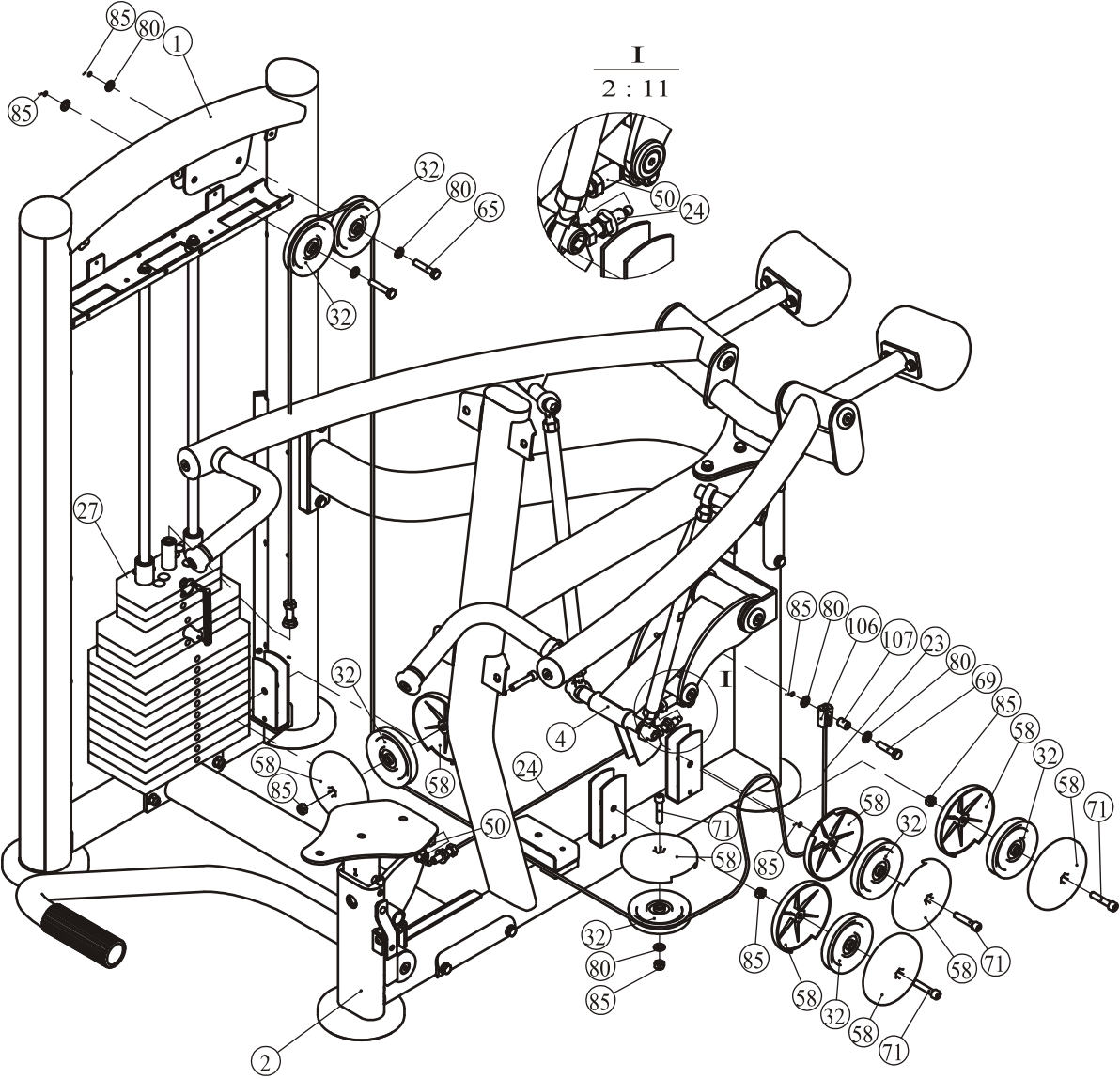

Assembly

STEP 6

- 1. Attach the Seat Pad (#34) to the Seat Pad Support (#12) using:
 - two M10*30 HHB (#66)
 - two $\Phi 11*\Phi 20*2$ Flat Washers (#80)
- 2. Attach the Back Pad (#33) to the Main Frame (#2) using:
 - four M10*30 HHB (#66)
 - four $\Phi 11*\Phi 20*2$ Flat Washers (#80)

Note: Wrench Tighten Bolts and Nylon Lock nuts.

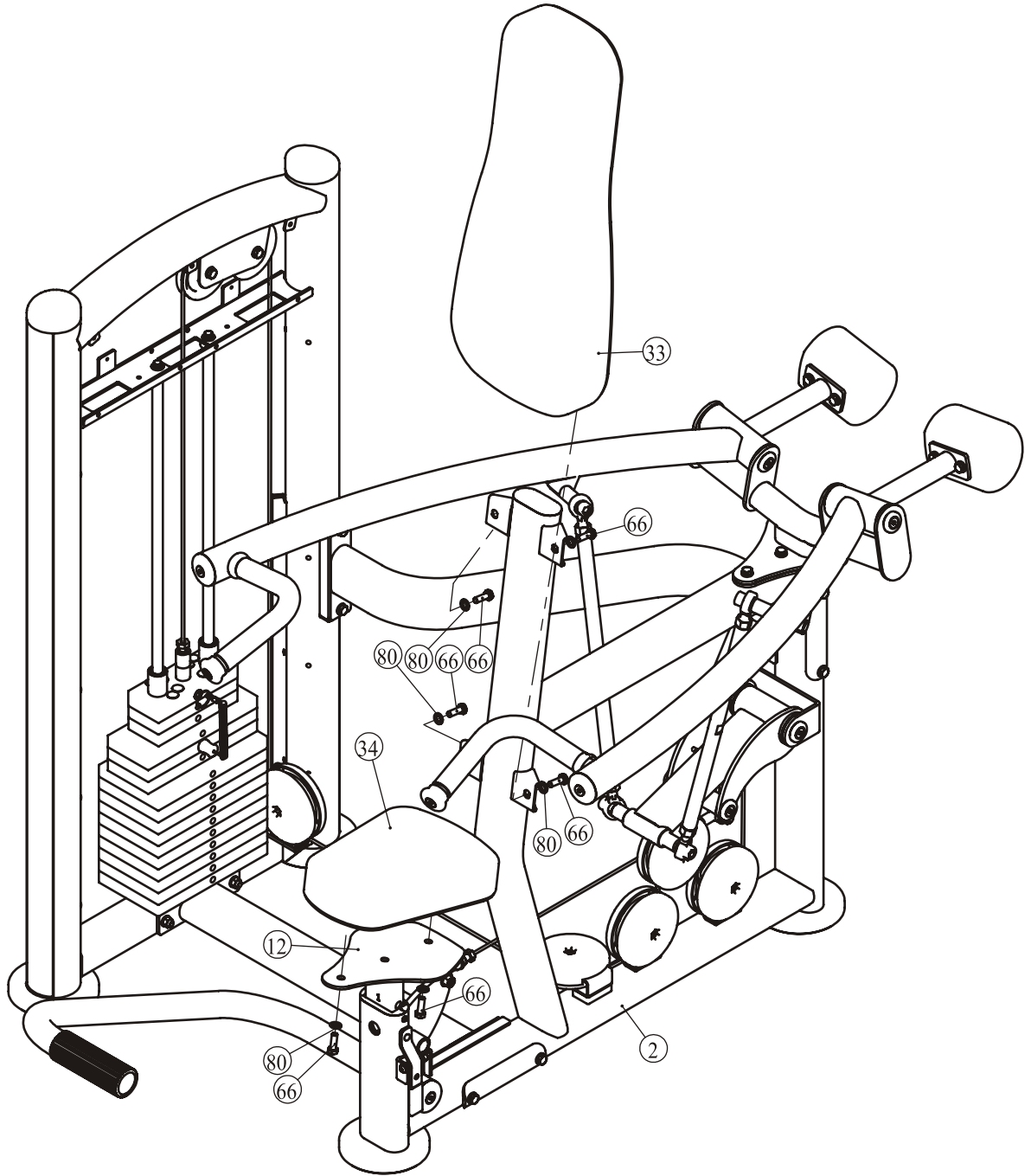

Assembly

STEP 7

1. Attach one Front Shroud (#29) and one Rear Shroud (#30) to the Weight Stack Frame (#1) using:
eight $\Phi 8 \times \Phi 20 \times 23$ Buttons (#59)
2. Attach the Top Front Shroud & The Front Support (#39 & #40) to the Weight Stack Frame (#1) using:
three M5*16 Flat Philips Screws (#77)
3. Attach the Top Rear Shroud-A (#111) and the Rear Support (#112) to the Weight Stack Frame (#1) using:
three $\Phi 8 \times \Phi 20 \times 23$ Buttons (#59) two M5*25 Flat Philips Screws (#113)

Note: Wrench Tighten Bolts and Nylon Lock nuts.

Here is the assembly instruction for **Flat Shroud !**

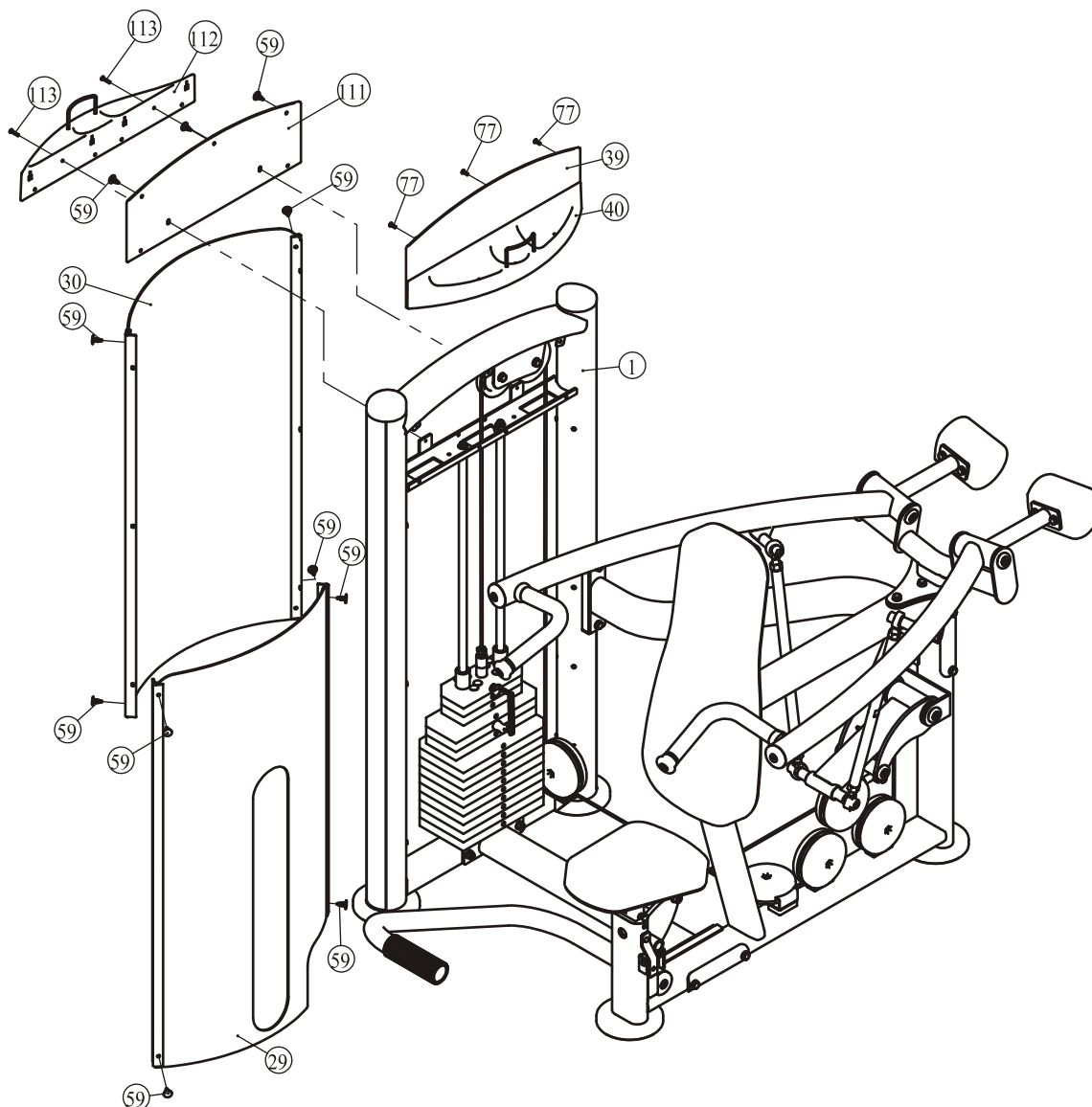

Assembly

STEP 7

1. Attach one Front Shroud (#29) and one Rear Shroud (#30) to the Weight Stack Frame (#1) using:
eight $\Phi 8 \times \Phi 20 \times 23$ Buttons (#59)
2. Attach the Top Front Shroud & The Front Support (#39 & #40) to the Weight Stack Frame (#1) using:
three M5*16 Flat Philips Screws (#77)
3. Attach the Top Rear Shroud-A (#111) and the Rear Support (#112) to the Weight Stack Frame (#1) using:
three $\Phi 8 \times \Phi 20 \times 23$ Buttons (#59) two M5*25 Flat Philips Screws (#113)

Note: Wrench Tighten Bolts and Nylon Lock nuts.

Here is the assembly instruction for Molding Shroud !

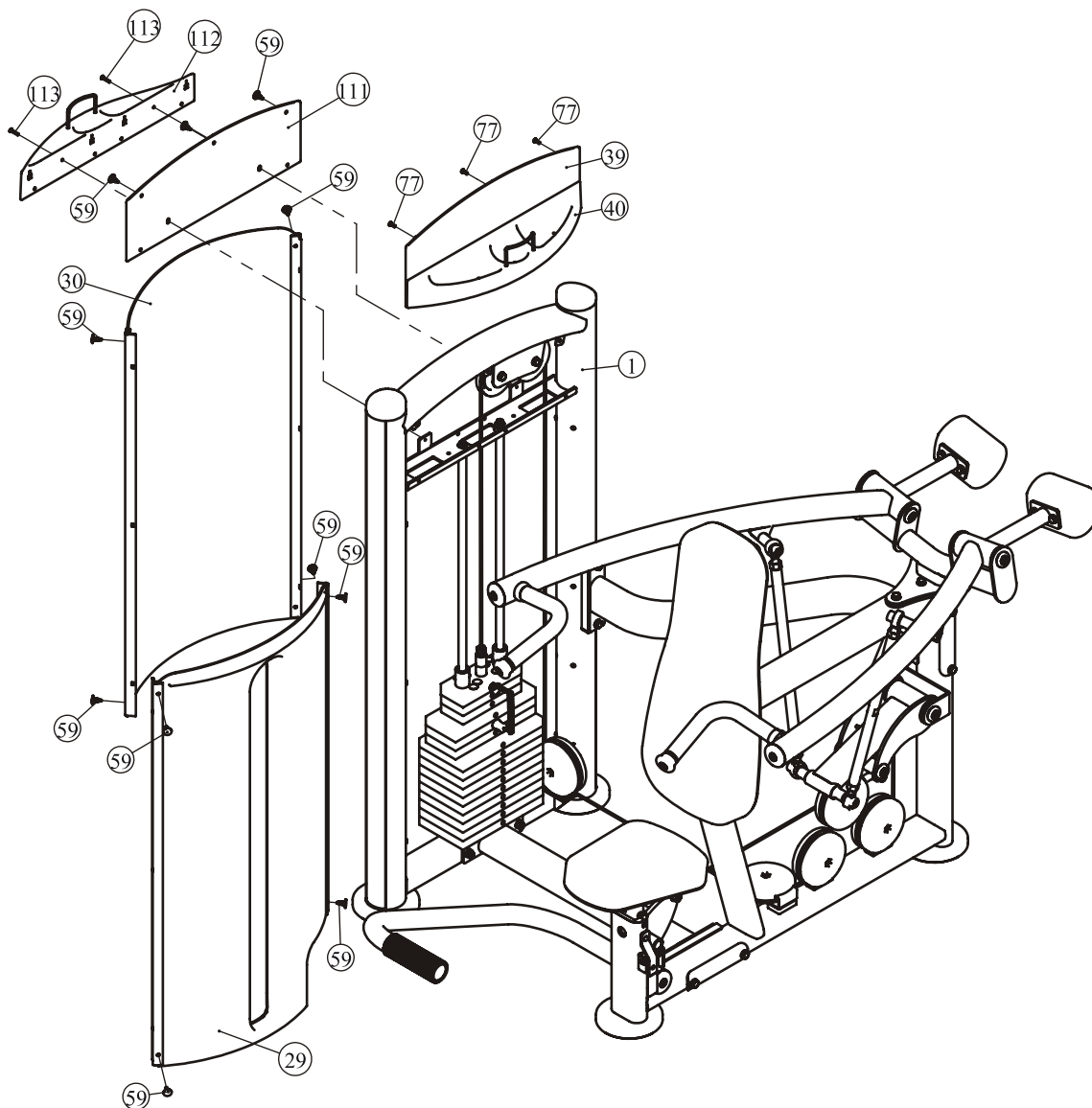

Assembly

STEP 7

1. Attach one Shroud (#37) to the Weight Stack Frame (#1) using:
four $\Phi 13 \times 3$ Plastic Washers (#89) four $\Phi 21 \times 5.7$ Plastic Covers (#88)
four $\Phi 18 \times 12$ Connect Button (#60) four ST4.2*10 Self-Tapping Screws (#78)
2. Attach the Top Front Shroud & The Front Support (#39 & #40) to the Weight Stack Frame (#1) using:
four $\Phi 8 \times \Phi 20 \times 23$ Buttons (#59) three M5*16 Flat Philips Screws (#77)
3. Attach the Top Rear Shroud (#38) to the Weight Stack Frame (#1) using:
five $\Phi 8 \times \Phi 20 \times 23$ Buttons (#59)

Note: Wrench Tighten Bolts and Nylon Lock nuts.

Here is the assembly instruction for **Short Shroud !**

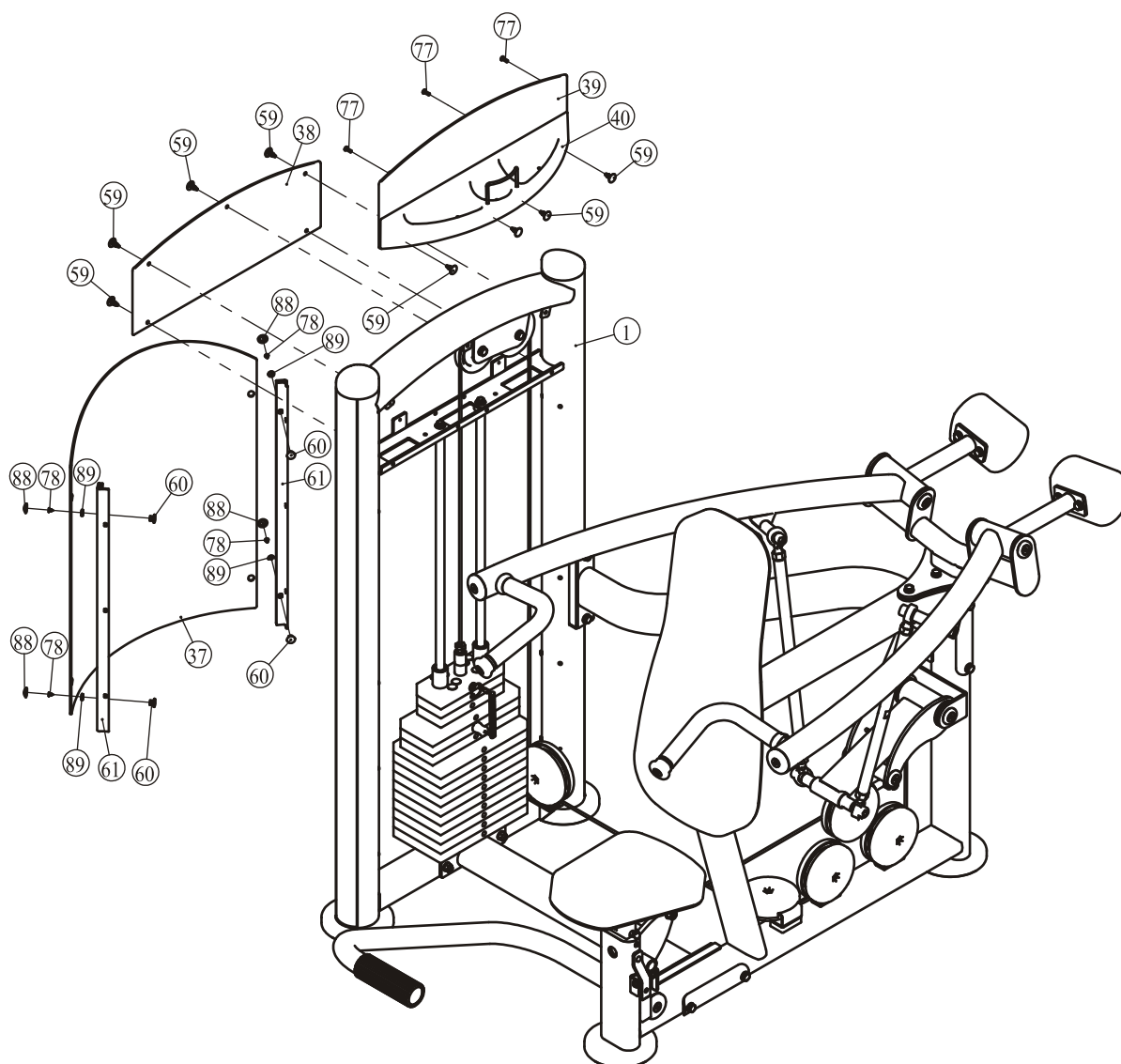

Adjust Instructions

Seat Pad adjustment

1. Push the Adjustable Support and adjust the Seat Pad to the desired position.
2. Make sure the pin get into the hole completely.

The use of Selector Pin

1. Select an appropriate weight and put the Selector Pin into the hole on it.
2. Make sure the Selector Pin gets into the hole completely.

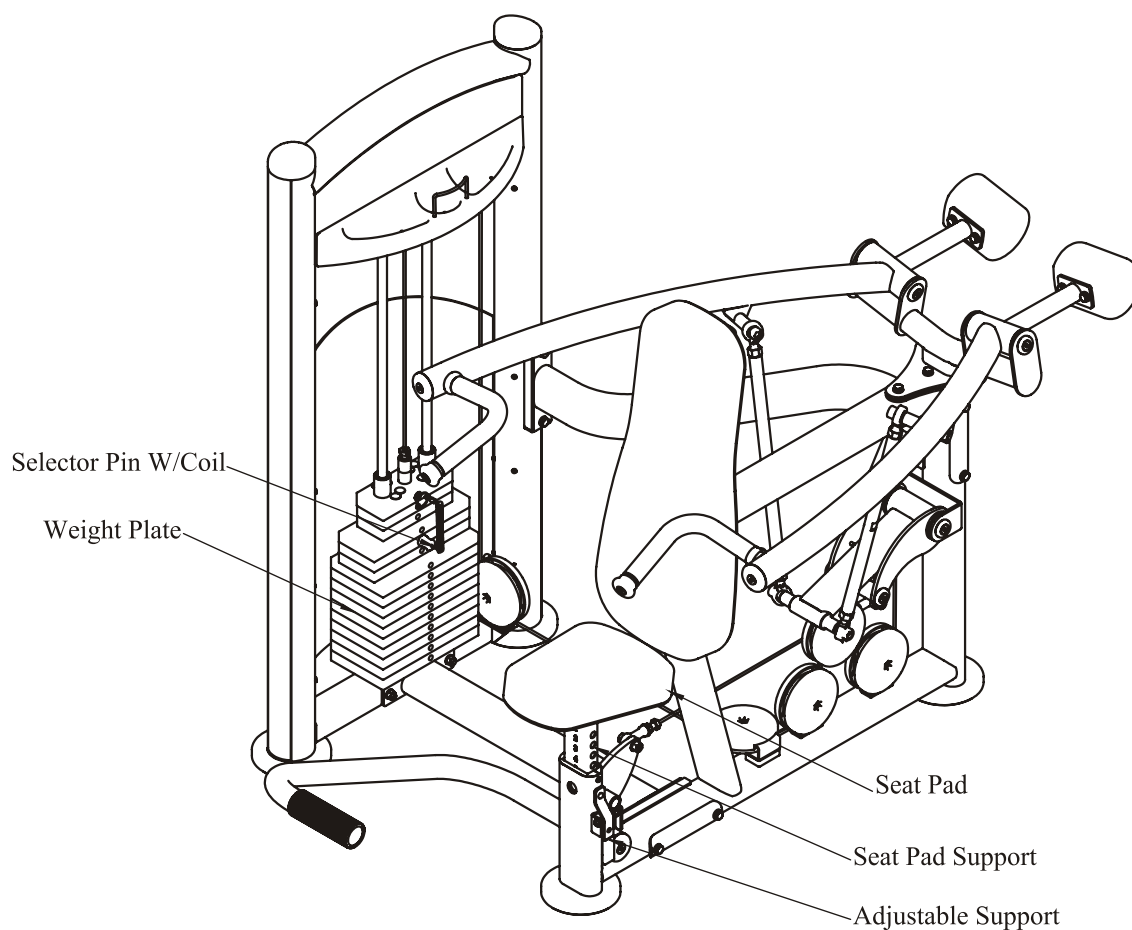

Exercise Instructions

SHOULDER PRESS

Start

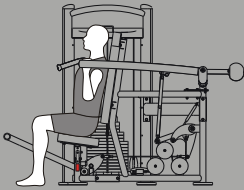

Finish

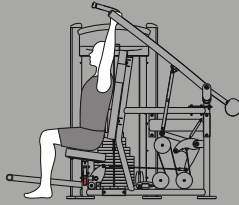

Exercise Instructions

1. Select an appropriate weight.
2. Adjust seat pad for desired positioning.
3. Press startup perch by one foot, hold bar, release startup foot slowly, press up slowly.
4. Slowly return to the starting position.

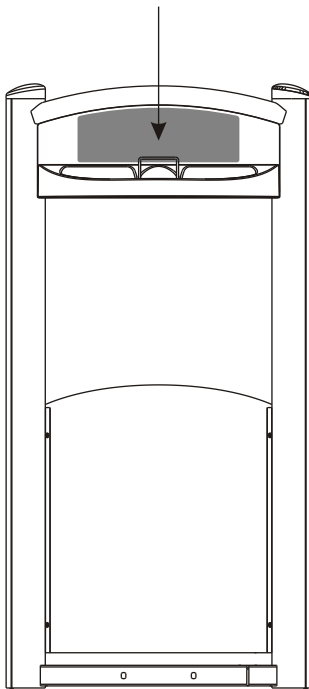
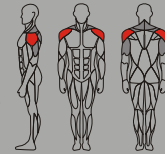

Exercise Instructions

1. Select an appropriate weight.
2. Adjust seat pad for desired positioning.
3. Press startup perch by one foot, hold bar, release startup foot slowly, press up slowly.
4. Slowly return to the starting position.
(Adjust weight according to the select pin)

Maintenance Schedule

ROUTINE	COMMERCIAL MAINTENANCE	HOME MAINTENANCE	LATEST DATE ENTRY						
Inspect; Links, Pull Pins, Snap Locks, Swivels, Weight Stack Pins	DAILY	WEEKLY							
Clean; Upholstery	DAILY	WEEKLY							
Inspect; Cables or Belts and their tension	DAILY	WEEKLY							
Inspect; Accessory Bars, and Handles	WEEKLY	3 MONTHS							
Inspect; All Decals	WEEKLY	3 MONTHS							
Inspect; All Nuts and Bolts, Tighten if needed	WEEKLY	3 MONTHS							
Inspect; Anti-Skid Surface	WEEKLY	3 MONTHS							
Clean & Lubricate; Guide Rods with a Teflon (PTFE) based lubricant (Superlube)	MONTHLY	3 MONTHS							
Lubricate; Seat Sleeves, Turcite Bushings, Linear Bearing	MONTHLY	3 MONTHS							
Clean and Wax; All Glossy Finishes	6 MONTHS	YEARLY							
Repack with Grease; Linear Bearings	6 MONTHS	YEARLY							
Replace; Cables, Belts and Connecting Parts	YEARLY	3 YEARS							

Your equipment comes with a commercial maintenance decal. For personal, in home use, please follow the home maintenance schedule listed above.

General Maintenance Information

Links, Pull-Pins, Snap Hooks, Swivels, Weight Stack Pins:

- * Check all pieces for signs of visible wear or damage.
- * Check springs in snap hooks and pull-pins for proper tension and alignment.
- * If the spring sticks or has lost its rigidity, replace it immediately.

Upholstery:

- * To ensure prolonged upholstery life and proper hygiene, all upholstered pads should be wiped down with a damp cloth after every workout.
- * Periodically take the time to use a mild soap or an approved vinyl upholstery cleaner to deter the onset of cracking or drying. Avoid using any abrasive cleaners or cleaners not intended for use on vinyl.
- * Replace ripped or worn upholstery immediately.
- * Keep sharp or pointed objects clear of all upholstery.

Decals:

- * Inspect and familiarize yourself with any safety warnings or other user information posted on each decal.

Nuts and Bolts:

- * Inspect all nuts and bolts for any loosening and tighten if needed.
- * Go through a re-tightening sequence periodically to ensure that all hardware is tensioned proper.

Anti-Skid Surfaces:

- * These surfaces are designed to supply secure footing and need to be replaced if they appear worn or become slippery.

Belts and Cables:

- * We use only high quality belt, and mil-spec cables.
- * Visually inspect the belts and cables for fraying, cracking, peeling or discoloration.
- * While the machine is not in use, carefully run your fingers along the belt or cable to feel for thinning or bulging areas.
- * Replace belts and cables immediately at the first signs of damage or wear. Do not use equipment until belts or cables have been replaced.

Belt and Cable Tension:

- * Referring to the Owners Manual, when belts or cables are used check all bolts attachments to be sure they are properly attached.
- * Check slack in cables and re-adjust cable tension if needed.

Seat Sleeves, Guide Rods:

- * Wipe down adjusting tubes with a dust free rag before applying lubricant.
- * Lubricate seat sleeves and Guide Rods with a Silicon or Teflon based lubricant spray.

Linear Bearings:

- * Referring to the Owners Manual carefully disassemble the bearing from its housing and place a finger full of light grease (lithium, super lube, etc.) into the inside of the bearing. Using your finger, press the grease into the ball-bearings and their tracks. Repeat until the ball-bearing tracks are full of grease. Insert the shaft back into the bearing and wipe off excess grease.

PLEASE KEEP THIS FOR YOUR RECORDS

Weight Training Tips

Use this manual to guide you through the basic exercises you can perform on your equipment. To gain maximum results and avoid possible injury, consult a fitness professional to develop your complete exercise program.

Always consult your physician before starting any exercise program.

To be successful in your exercise program, it is important to develop an understanding of the basic principles of strength training. Now that you have your equipment, it is only natural that you want to get started immediately. First, determine a set of realistic goals and objectives for yourself. By deciding on an exercise plan that is right for you prior to starting, you will contribute significantly to your success.

Warm up properly before engaging in weight resistance training. Stretching, yoga, jogging, calisthenics or other cardiovascular exercise can help prepare your body for the heavier workload of lifting weights.

Learn how to perform the exercise correctly before using heavy weight. Correct form is important to avoid injury and to ensure that you work the proper muscle groups.

Know your limitations. If you are new to weight training or are embarking on an exercise regimen after a long layoff, start slowly and build foundational strength over a longer period of time.

Pay attention to your breathing. Exhale when you exert is a general rule of thumb. Never hold your breath.

